



MX-X

MX-Q

MX-X, MX-Q Technical Data.

Order picking forklift truck
with turret head.

Order picking forklift truck
with telescopic forks.



Order picking forklift truck with turret head/ telescopic forks.

STILL presents the modern and forward looking MX-X truck concept with OPTISPEED.

These are the features of this generation of trucks:

- Modular construction.
- Flexible in use.
- Scaleable dimensions and performance.
- Ergonomic workplace.
- High turnaround of goods.
- Low energy consumption.
- Low operating costs.
- OPTISPEED, the futuristic concept available today.

Modern and efficient technology.

- Energy recovery under braking and when lowering the main lift.
- The highly efficient 3-phase drive motor provides superior performance at lower operating costs and is wear free for increased uptime and greater throughput.
- Peak speeds are available even when lowering unladen in auxiliary lift.
- Powerful, low wear hydraulics.
- Sensitive secondary movements thanks to proportional valve technology.
- Powerful, effective speed regulated hoist movements, thanks to on-off valve technology.
- Particularly low wear due to low working pressure and integral high pressure filter.
- Compact and stable construction for optimal use of space and safe working even at extreme heights.
- Smaller aisle widths or greater safety clearances due to the turret head with integral overreach.
- Integral height measurement system for precise positioning of the forks.
- Maximum residual capacity due to optimal matching of the truck width to the aisle width.
- Quick, trouble-free entry into the aisle due to the new variably adjustable, mechanical rail guidance.

The mobile workplace.

- Highly ergonomic and comfortable driving.
- Low, generous entry step.
- Protected against noise and draughts.
- Optimal visibility due to clear glass panelling.
- Shock absorbent cab concept.
- Comfortable, ergonomic seat for driving and order picking.
- Adjustable height with folding seat - a match for any task.
- Generous footwell for feet and knee.
- Integral storage facilities complete the mobile workplace.
- Adapted Materialflow Management System.

The operating panel.

- Simple, safe handling, all functions can be executed without changing grip.
- Driving simultaneous with hoisting/lowering.
- Lowering of main and auxiliary lift.
- Synchronous swivel shift movement.
- Simple, clear operator guidance through up to date display of the truck states.
- Relieves the strain on the whole body due to posture tolerant operation. Whether sitting or standing, the operating panel goes with the operator.
- Performance order picking without stress, everything in view and lots of space.

Cab variants.

The MX-X always has the right solution for all applications, whether order picking, moving goods into or out of stock or a combination of these.

- Combi: for order picking and/or stacking operation.
- Stacker: with seat position raised by 125 mm and additional footplate for stacking operation with a better view of the forks.
- Comfort: 200 mm deeper, for order picking and/or stacking operation with more space and more seating comfort.
- Enclosed cab: with panoramic windows, for unheated warehouses to 0°C. Pleasant climate due to ventilation system and optional heating system.
- TK Cab: enclosed with panoramic windows, ideal for cold store applications down to -30°C. Comfortable climate due to ventilation system and powerful heating system.

OPTISPEED Version 3.x - the control concept that shows the way to the future.

Excellent performance data and optimal technical characteristics of the MX-X are only fully utilised by OPTISPEED 3.x, both when driving and hoisting and also in the secondary movements.

- Powerful microprocessor drive and hoist pulse controller. The individual controllers, sensors and actuators are linked by a CAN bus.
- The CAN bus with CAN open protocol offers high flexibility and fast access through the central interface.
- The height measurement system provides the absolute fork height. Due to the non-slip, reliable height sensing, even when incorporating the auxiliary lift, performance optimised driving profiles and load change cycles can be realised.

Features.

- Made to measure by selection and suitable combination of the drives.
- Quick load changes thanks to automatic adjustment of the deceleration and acceleration ramps.
- Dynamic, intelligent load diagram for greater safety in the warehouse.
- Increased turnaround of loads due to synchronous slewing in the aisle and in front of the racking supplied as standard.
- Increase in performance due to the optional load sensing and weight measurement equipment.
- Less damage to the truck, goods and equipment due to individual adjustment of the speeds, end positions, acceleration and deceleration to the application conditions.
- Greater functional convenience and safety as all moving axes are continuously measured and monitored.
- Effective, fast configuration, diagnosis and maintenance is made possible by the central interface (via Modem or with the Service Tool Box).
- Fast reaction time due to immediate on-board diagnosis at the operating panel.
- Reliable, fast commissioning due to the "Teach-in" process for the major functions directly at the operating panel.
- Individual driver settings possible, as ergonomics and driver comfort can be specifically adjusted to the application conditions and the operator, to optimise performance.
- Improved access control thanks to PIN code instead of key (optional).
- Integral height pre-selection in the multi-function operating panel for fast, reliable and comfortable height positioning (optional).
- Automatic fork cycle for easy, fast load changes.

Driver's cab.

- The STILL driver's cab has been designed using knowledge of ergonomics and occupational medicine and offers an optimal workplace for a variety of applications.
- The driver's cab has low vibration mountings. This reduces the transmission of vibrations coming from the load.
 - Ergonomically adjustable operating panel with display panel, integrated into the driver's cage wall, guarantees optimal access to the controls whether standing or sitting.
 - Standardised STILL operating philosophy on all narrow aisle trucks.
 - Steering knob shaped for the hand allows precise truck movements. All other movements are controlled through two small multi-function levers, to the left and right. 2-handed operation is optimally integrated, unnoticeable by the driver. Simultaneous lowering of auxiliary lift and main lift, and also diagonal travel in aisles. Impact button for emergency off, horn, and also a push button for all functions requiring confirmation.
 - Padded cloth covered folding seat with seat height adjustment allows relaxed sitting when stacking and provides room to move freely when order picking.
 - Cab and front end designed for adequate knee and foot clearance, with storage facilities.
 - Side doors consist of triple barriers.
 - The best view onto forks and roadway - even when seated.
 - Low cab entry step for comfortable entry and exit.
 - The truck will only drive when the travel switch (dead man principle) is depressed and the cab doors are closed.
 - Monitoring equipment prevents damage and allows planning of downtime.

Steering.

- Electrical steering acting directly through a gear on the drive unit. Integral steering knob on the operating panel.
- Free ranging, mechanical or inductive guidance in racking aisles, with automatic straight ahead setting of the steered drive wheel and contactless aisle recognition.

Chassis.

- Torsionally rigid steel structure with large load rollers for high driving comfort.
- Drive compartment covered with a plastic hood, which can be taken off to the rear. Battery lid also in impact resistant "Mastershock" plastic. Optional removable battery side plates to protect the battery and round off the overall image of the chassis design.

Masts.

- "Light" telescopic mast optimised for smaller loads up to 1000 kg.
- Telescopic mast as the ideal standard solution.
- Triplex mast with free-lift where girders, door openings or fittings require a low closed mast height.
- Three point mast construction, stable and torsionally rigid for pleasant working conditions even at extreme heights.
- High overall heights additionally stabilised by mast bracing.
- Various masts for auxiliary lift.
- Mast bracing.

MX-X Turret head with auxiliary lift.

A functional group for load pick-up on three sides with integral controller and hydraulics. Unnecessarily long connections such as cables and hydraulic hoses are avoided, increasing the operating reliability in the long term. Diagnosis and maintenance becomes easier and faster.

- High flexibility due to synchronous rotation, which allows left and right sides of the aisle to be serviced in the same run.
- The auxiliary lift means that only a small mass has to be moved for a precise approach to the pallet location, saving energy.
- When putting goods into and out of stock the overall lift height increases; optimal utilisation of space up to the ceiling saves money.
- When order picking the pallet can be brought to the most favourable height for depositing goods.
- High load turn round due to a simultaneous lowering with the main lift.
- High lowering speed even with a small load on the forks.

Hydraulics.

The truck is equipped as standard with proportional valve technology for particularly sensitive, smooth control of the secondary movements. The hoist pulse controller controls the pump speed for the main lift through on-off valves for the greatest effectiveness.

- All movements can be individually adjusted to the application conditions.
- All end of stroke positions are approached gently and smoothly.
- Running the hoist motor as a generator when lowering allows an energy recovery of up to 15%.
- The bypass concept when lowering the main lift allows sensitive, precise positioning.

Three-phase technology drive.

Low wear, low maintenance drives combined with off-load switching MOSFET technology are the basis for a powerful, robust and economical drive concept.

- Drive modules in 48 V and 80 V.
- Monitoring and display of the drive states for effective preventive maintenance.
- The enclosed air-cooled three-phase motor does not move with the steering, so there are no stressed cable connections.
- Generously dimensioned gearbox and drive wheel for high driving comfort and safety.
- High torque and peak speeds with particularly sensitive control for driving independent of the load, economical in energy consumption and maintenance, with above average running power.

Brake system.

- The service brake is a generator brake. An electrical spring-loaded brake is used for parking/securing and as an emergency stop.
- Two braking systems independent of each other work practically wear free.
- Optional load wheel brake to increase the braking and driving performance.

CAN bus.

- All controls, sensors and actuators are networked with each other.
- High flexibility due to central access to all units and functions.
- High level of safety due to proven technology from the car and commercial vehicle field.
- Less wiring and fewer sensors for additional operating safety, in the long term as well.

Battery compartment.

Battery changing from both sides using a forklift truck or a battery changing frame.

Battery.

- For multi-shift use battery changing using various battery changing systems or a forklift truck.
- Batteries in 48 V and 80 V versions for different power classes.
 - The overall energy balance is up to 40% better allowing the use of a smaller battery for the same turnaround of goods (or longer usage times) without interim charging or battery changes.

Auxiliary equipment:

Driver's cab.

- Workplace lighting, working spot lights into racking.
- Side and centrally mounted rear view mirrors.
- Padding for barriers.
- Writing surface with document clip.
- Wind protection at load end, glass screen integrated in wall.
- Fully glazed swing doors for side-wind protection.
- Fan on the overhead guard.
- Preliminary set-up for radio installation integrated in overhead guard.
- Cabs: Combi, Stacker, Comfort, Enclosed-cab and Cold Store cab down to -30° C.
- Various seat options (high backrest, heated, air-sprung, several adjustment possibilities, etc.).
- Reversing camera for all round visibility in the drive direction: supplementary to the mirrors, with a display mounted on the front panel; mirror replacement by a left hand/right hand display in the enclosed cab.

Driving.

- Guidance, mechanical or inductive.

Chassis.

- Different chassis and cab widths.
- Antistatic version.

Turret head.

- Fork carriages for different pallets.
- Various attachments.
- Overreach for turret head.
- Hydraulic turret head functions.
- Tooth flank guard in the area of turret head (recommended for bagged goods).
- 3 variants of hydraulic fork adjustment.
- Load sensing.
- Weight sensing.
- Weight measurement.
- Fork sideshift cut-out.

Drives.

- Modules to increase performance and residual capacity.
- Cold store version.

Battery compartment and battery.

- Different battery trays for 48 V and 80 V voltage classes.
- Battery roller track for side changes.
- Battery is secured at the side and electronically monitored.
- Battery compartment side covers.
- Cable set for spare battery.

Service and maintenance.

- Standardised interface for data terminal.
- Topping-up aid for hydraulic oil.
- The STILL Service Tool Box allows easy configuration, parameter setting and diagnosis.
- Central Service and diagnostic interface for connection of the STILL Service Tool Box.
- Long term memory for malfunctions and display for error code.
- On-board diagnosis using menu keys on the operating panel.
- Drive compartment and rear hood also designed for easy access from the aisle.
- Battery cover is opened from above for maintenance purposes and provides a service platform.
- Particularly low wear hydraulics due to integral high pressure filter.
- Remote diagnosis and maintenance support possible through Online X-module.

Safety, design and ergonomics.

- The truck is built in accordance with the EC guideline 98/37/EC and thus carries the CE symbol.
- STILL is certified to ISO 9001.
- Automatic braking at end of aisle, various designs.
- Hoist cut-outs and various drive cut-outs.
- Contactless collision protection on the overhead guard with all-round scanning.
- Mobile personal protection equipment.
- PIN code access.
- Additional braking system.
- Safety package compliant with CE conformity.
- All drive and hoist movements are made safe through the deadman foot switch and the two handed operation.
- Rounded shapes and smooth padded surfaces with many integral storage facilities.
- Abseil equipment integrated in the overhead guard, accessible quickly and without tools.
- Emergency lowering valve under the rear hood, also easily accessible from the aisle.
- OPTISPEED for additional safety in all functions, height dependent and redundant.

Automation components (optional).

- Materialflow Management on-line using radio, increases efficiency by issuing paperless orders and efficient material flow control. Up to 30% greater turnaround of goods with virtually 0 errors. Integral mobile personal protection equipment provides extremely high safety in the aisle.
- Automatic fork cycle.
 - Lift height pre-selection.
 - Data terminal with data transfer, printer, scanner and interface to the STILL MMS.
 - Semi-automatic shelf approach OPTISPEED 4.0.
 - Automation interface for unmanned fully automatic operation.

Order picking forklift truck with telescopic forks.

Characteristics	1.1	Manufacturer			STILL	STILL	
	1.2	Manufacturer's model designation			MX-X Telescopic mast	MX-X Triplex mast with free lift	
	1.3	Drive (electric, diesel, petrol, LPG, Mains electric)			Electric	Electric	
	1.4	Controls			Stand-on / Seated	Stand-on / Seated	
	1.5	Capacity / load	Q	kg	500 - 1500	500 - 1500	
	1.6	Load centre	c	mm	600	600	
	1.9	Wheel base	y	mm	1586 - 2184	1586 - 2184	
Weights	2.1	Truck weight		kg	variable*	variable*	
	2.2	Axle load laden	drive end / load end	kg	variable*	variable*	
	2.3	Axle load unladen	drive end / load end	kg	variable*	variable*	
Wheels chassis	3.1	Tyres (rubber, pneumatic, polyurethane)			Polyurethane	Polyurethane	
	3.2	Tyre diameter / width	drive end	mm	400/140	406/170	
	3.3	Tyre diameter / width	load end	mm	370/160	370/160	
	3.5	Number of wheels (x=driven)	drive end/load end		1x/2	1x/2	
	3.6	Track width	load end	b ₁₀	mm	variable*	variable*
	3.7	Track width	drive end	b ₁₁	mm	0	0
	Basic dimensions	4.2	Height, mast lowered	h ₁	mm	2400 - 7400	2900 - 5900
4.3		Free lift	h ₂	mm	-	1650 - 4650	
4.4		Lift	h ₃	mm	2200 - 11800	5050 - 12850	
4.5		Height, mast raised	h ₄	mm	4755 - 14355	7605 - 15405	
4.7		Height over overhead guard (cab)	h ₅	mm	2555	2555	
4.8		Seat / platform height	h ₇	mm	430	430	
4.11		Aux. fork lift	h ₉	mm	1675 - 2375	1675 - 2375	
4.14		Height, platform raised	h ₁₂	mm	2645 - 12245	5495 - 13295	
4.14.1		Pick height (h ₁₂ + 1600 mm)	h ₂₈	mm	4245 - 13845	7095 - 14895	
4.15		Lowered height	h ₁₃	mm	80	80	
4.19		Overall length (including forks)	l ₁	mm	variable*	variable*	
4.21		Overall width	Chassis/load wheel axle	b ₁ /b ₂	mm	1160 / 1160 - 1800	1160 / 1160 - 1800
4.22		Fork dimensions		s/e/l	mm	variable*	variable*
4.24		Fork carriage width		b ₃	mm	variable*	variable*
4.25		Overall fork width		b ₅	mm	variable*	variable*
4.27		Width over guide rollers		b ₆	mm	1170 - 1919	1170 - 1919
4.29		Shift, to side		b ₇	mm	variable*	variable*
4.31		Floor clearance under mast, laden		m ₁	mm	40	40
4.32		Floor clearance, centre of wheel-base		m ₂	mm	87	87
4.34		Working aisle width		A _{st}	mm	variable*	variable*
4.35		Turning radius		W _s	mm	variable*	variable*
4.38	Distance to turret head pivot point		l ₈	mm	variable*	variable*	
4.39	Length of traverse arm		A	mm	variable*	variable*	
4.40	Width, side-shift carriage		B	mm	variable*	variable*	
4.41	Width of traverse arm		F	mm	variable*	variable*	
4.42	Transfer aisle width	min.	A _u	mm	variable*	variable*	
Performance	5.1	Travel speed	(laden / unladen)	km/h	variable*	variable*	
	5.2	Hoist speed	(laden / unladen)	m/s	variable*	variable*	
	5.3	Lowering speed	(laden / unladen)	m/s	variable*	variable*	
	5.4	Shift speed	(laden / unladen)	m/s	variable*	variable*	
	5.9	Acceleration time (over 10 m)	(laden / unladen)	s	variable*	variable*	
	5.10	Service brake			Generator	Generator	
E-Motor	6.1	Drive motor, rating S2 = 60 min		kW	7	7	
	6.2	Hoist motor, rating at S3 = 15%		kW	20 - 24	20 - 24	
	6.3	Battery to IEC 254-2; A, B, C, No			IEC 254-2; A	IEC 254-2; A	
	6.4	Battery type, voltage, capacity C5		V/Ah	PzS, 48 V**, 480 - 1240 Ah/ PzS, 80 V, 420 - 930 Ah	PzS, 48 V**, 480 - 1240 Ah/ PzS, 80 V, 420 - 930 Ah	
	6.5	Battery weight ± 5% (depends on make)		kg	1238 - 2310	1238 - 2310	
Misc	8.1	Drive control			Microprocessor	Microprocessor	
	8.4	Noise level, at driver's ear		dB(A)	68	68	

* The figures are scaleable and conform to the customer's individual requirements.

** 48 V power class not available for all configurations.

Telescopic mast.

(all height details are given in mm)

Overall height h_1	Total lift from floor h_{25} ($h_3+h_9+h_{13}$)	Total lift h_{24} (h_3+h_9)	Main lift h_3	Lowered height h_{13}	Aux. lift h_9	Platform height h_{12} (h_3+h_7)	Pick height h_{28} (h_7+1600)	Max. height h_4 (h_3+h_5)
7,400	13,535	13,475	11,800	60	1,675	12,245	13,845	14,355
6,900	12,535	12,475	10,800	60	1,675	11,245	12,845	13,355
6,400	11,735	11,675	10,000	60	1,675	10,445	12,045	12,555
5,900	10,735	10,675	9,000	60	1,675	9,445	11,045	11,555
5,400	9,935	9,875	8,200	60	1,675	8,645	10,245	10,755
4,900	8,935	8,875	7,200	60	1,675	7,645	9,245	9,755
4,400	7,935	7,875	6,200	60	1,675	6,645	8,245	8,755
3,900	6,935	6,875	5,200	60	1,675	5,645	7,245	7,755
3,400	5,935	5,875	4,200	60	1,675	4,645	6,245	6,755
2,900	4,935	4,875	3,200	60	1,675	3,645	5,245	5,755
2,400	3,935	3,875	2,200	60	1,675	2,645	4,245	4,755

(Telescopic masts optimised for 1000 kg up to $h_1 = 4900$ mm)

Triplex mast with free lift.

(all height details are given in mm)

Overall height h_1	Total lift from floor h_{25} ($h_3+h_9+h_{13}$)	Total lift h_{24} (h_3+h_9)	Main lift h_3	Free lift h_2 ($h_1 - 1250$)	Lowered height h_{13}	Aux. lift h_9	Platform height h_{12} (h_3+h_7)	Pick height h_{28} (h_7+1600)	Max. height h_4 (h_3+h_5)
5,900	14,585	14,525	12,850	4,650	60	1,675	13,295	14,895	15,405
5,400	13,285	13,225	11,550	4,150	60	1,675	11,995	13,595	14,105
4,900	11,785	11,725	10,050	3,650	60	1,675	10,495	12,095	12,605
4,400	10,485	10,425	8,750	3,150	60	1,675	9,195	10,795	11,305
3,900	9,185	9,125	7,450	2,650	60	1,675	7,895	9,495	10,005
3,400	8,085	8,025	6,350	2,150	60	1,675	6,795	8,395	8,905
2,900	6,785	6,725	5,050	1,650	60	1,675	5,495	7,095	7,605

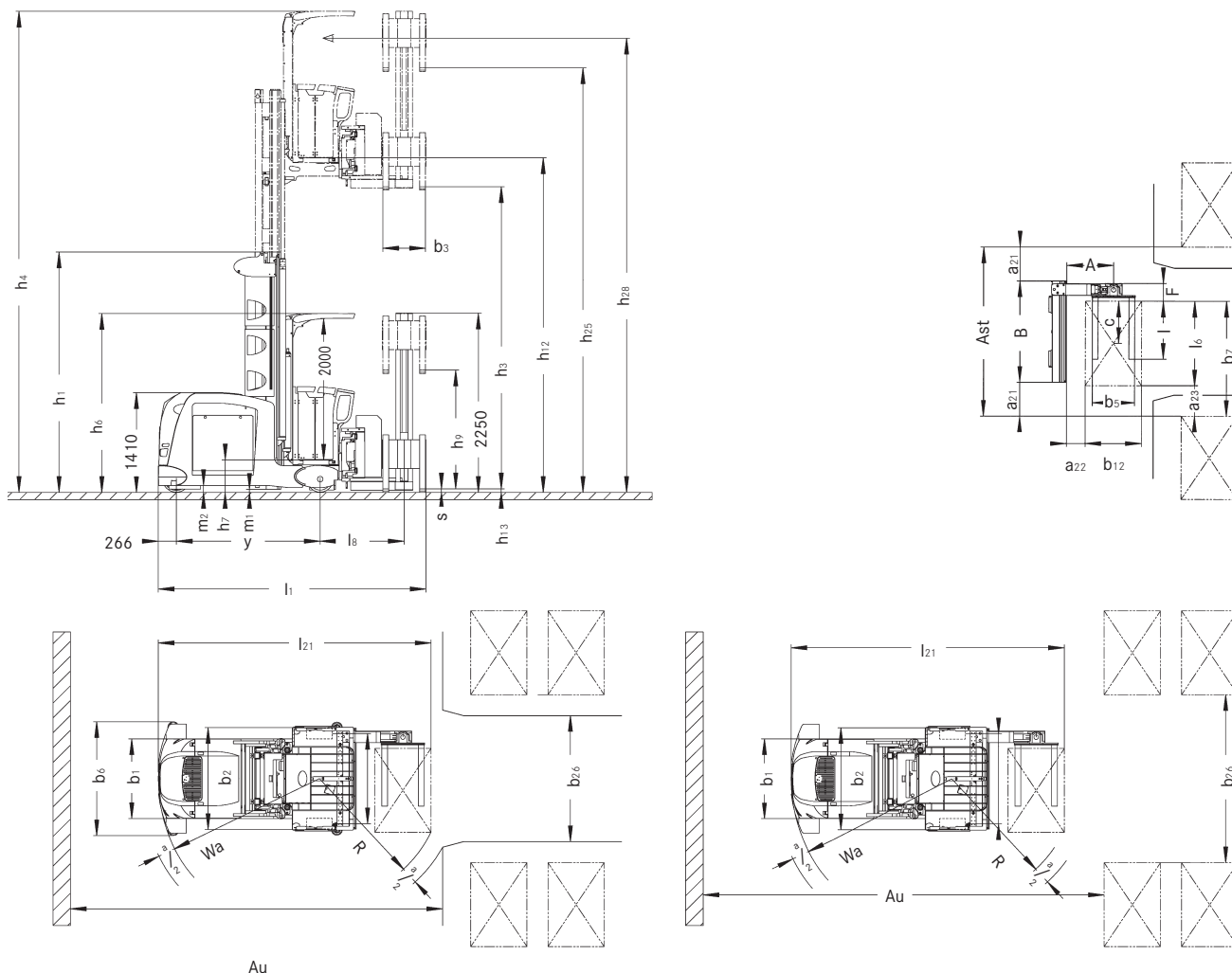

MX-Q Order picking forklift truck with telescopic forks.

				STILL	STILL		
Characteristics	1.1	Manufacturer					
	1.2	Manufacturer's model designation		MX-Q Telescopic mast	MX-Q Triplex mast with free lift		
	1.3	Drive (electric, diesel, petrol, LPG, Mains electric)		Electric	Electric		
	1.4	Controls		Stand-on / Seated	Stand-on / Seated		
	1.5	Capacity / load	Q	kg	500 - 1250	500 - 1250	
	1.6	Load centre	c	mm	600	600	
	1.9	Wheel base	y	mm	1586 - 2184	1586 - 2184	
Weights	2.1	Truck weight		kg	variable*		
	2.2	Axle load laden	drive end / load end	kg	variable*		
	2.3	Axle load unladen	drive end / load end	kg	variable*		
Wheels chassis	3.1	Tyres (rubber, pneumatic, polyurethane)			Polyurethane		
	3.2	Tyre diameter / width	drive end	mm	400/140	406/170	
	3.3	Tyre diameter / width	load end	mm	370/160	370/160	
	3.5	Number of wheels (x=driven)	drive end / load end		1x/2	1x/2	
	3.6	Track width	load end	b ₁₀	mm	variable*	
	3.7	Track width	drive end	b ₁₁	mm	-	
	Basic dimensions	4.2	Height, mast lowered		h ₁	mm	2400 - 7400
4.3		Free lift		h ₂	mm	-	1650 - 4650
4.4		Lift		h ₃	mm	2200 - 11800	5050 - 12850
4.5		Height, mast raised		h ₄	mm	4755 - 14355	7605 - 15405
4.7		Height over overhead guard (cab)		h ₅	mm	2555	2555
4.8		Seat / platform height		h ₇	mm	430	430
4.11		Aux. fork lift		h ₉	mm	800 - 1500	800 - 1500
4.14		Height, platform raised		h ₁₂	mm	2645 - 12245	5495 - 13295
4.14.1		Pick height (h ₁₂ + 1600 mm)		h ₂₈	mm	4245 - 13845	7095 - 14895
4.15		Lowered height		h ₁₃	mm	380	380
4.19		Overall length (including forks)		l _i	mm	variable*	variable*
4.21		Overall width	Chassis/load wheel axle	b ₁ /b ₂	mm	1160 / 1160 - 1800	1160 / 1160 - 1800
4.22		Fork dimensions		s/e/l	mm	variable*	variable*
4.24		Fork carriage width		b ₃	mm	-	-
4.25		Overall fork width		b ₅	mm	variable*	variable*
4.27		Width over guide rollers		b ₆	mm	1170 - 1919	1170 - 1919
4.29		Shift, to side		b ₇	mm	variable*	variable*
4.31		Floor clearance under mast, laden		m ₁	mm	40	40
4.32		Floor clearance, centre of wheel-base		m ₂	mm	87	87
4.34		Working aisle width		A _{st}	mm	variable*	variable*
4.35	Turning radius		W _a	mm	variable*	variable*	
4.38	Distance to turret head pivot point		l ₈	mm	variable*	variable*	
4.39	Length of traverse arm		A	mm	-	-	
4.42	Transfer aisle width		min. A _u	mm	variable*	variable*	
Performance	5.1	Travel speed	(laden / unladen)	km/h	variable*	variable*	
	5.2	Hoist speed	(laden / unladen)	m/s	variable*	variable*	
	5.3	Lowering speed	(laden / unladen)	m/s	variable*	variable*	
	5.4	Shift speed	(laden / unladen)	m/s	variable*	variable*	
	5.9	Acceleration time (over 10 m)	(laden / unladen)	s	variable*	variable*	
	5.10	Service brake				generator	generator
E-Motor	6.1	Drive motor, rating S2 = 60 min		kW	7	7	
	6.2	Hoist motor, rating at S3 = 15%		kW	20 - 24	20 - 24	
	6.3	Battery to IEC 254-2; A, B, C, No			IEC 254-2; A	IEC 254-2; A	
	6.4	Battery type, voltage, capacity C5		V/Ah	PzS, 48 V**, 480 - 1240 Ah/ PzS, 80 V, 420 - 930 Ah	PzS, 48 V**, 480 - 1240 Ah/ PzS, 80 V, 420 - 930 Ah	
	6.5	Battery weight ± 5% (depends on make)		kg	1238 - 2310	1238 - 2310	
Misc	8.1	Drive control			Microprocessor	Microprocessor	
	8.4	Noise level, at driver's ear		dB(A)	68	68	

* The figures are scaleable and conform to the customer's individual requirements.

** 48 V power class not available for all configurations.

Telescopic mast.

(all height details are given in mm)

Overall height h_1	Total lift from floor h_{25} ($h_3+h_9+h_{13}$)	Total lift h_{24} (h_3+h_9)	Main lift h_3	Lowered height h_{13}	Aux. lift h_9	Platform height h_{12} (h_3+h_7)	Pick height h_{28} (h_7+1600)	Max. height h_4 (h_3+h_5)
7,400	12,980	12,600	11,800	380	800	12,245	13,845	14,355
6,900	11,980	11,600	10,800	380	800	11,245	12,845	13,355
6,400	11,180	10,800	10,000	380	800	10,445	12,045	12,555
5,900	10,180	9,800	9,000	380	800	9,445	11,045	11,555
5,400	9,380	9,000	8,200	380	800	8,645	10,245	10,755
4,900	8,380	8,000	7,200	380	800	7,645	9,245	9,755
4,400	7,380	7,000	6,200	380	800	6,645	8,245	8,755
3,900	6,380	6,000	5,200	380	800	5,645	7,245	7,755
3,400	5,380	5,000	4,200	380	800	4,645	6,245	6,755
2,900	4,380	4,000	3,200	380	800	3,645	5,245	5,755
2,400	3,380	3,000	2,200	380	800	2,645	4,245	4,755

(Telescopic masts optimised for 1000 kg up to $h_1 = 4900$ mm)

Triplex mast with free lift.

(all height details are given in mm)

Overall height h_1	Total lift from floor h_{25} ($h_3+h_9+h_{13}$)	Total lift h_{24} (h_3+h_9)	Main lift h_3	Free lift h_2 ($h_1 - 1250$)	Lowered height h_{13}	Aux. lift h_9	Platform height h_{12} (h_3+h_7)	Pick height h_{28} (h_7+1600)	Max. height h_4 (h_3+h_5)
5,900	14,030	13,650	12,850	4,650	380	800	13,295	14,895	15,405
5,400	12,730	12,350	11,550	4,150	380	800	11,995	13,595	14,105
4,900	11,230	10,850	10,050	3,650	380	800	10,495	12,095	12,605
4,400	9,930	9,550	8,750	3,150	380	800	9,195	10,795	11,305
3,900	8,630	8,250	7,450	2,650	380	800	7,895	9,495	10,005
3,400	7,530	7,150	6,350	2,150	380	800	6,795	8,395	8,905
2,900	6,230	5,850	5,050	1,650	380	800	5,495	7,095	7,605

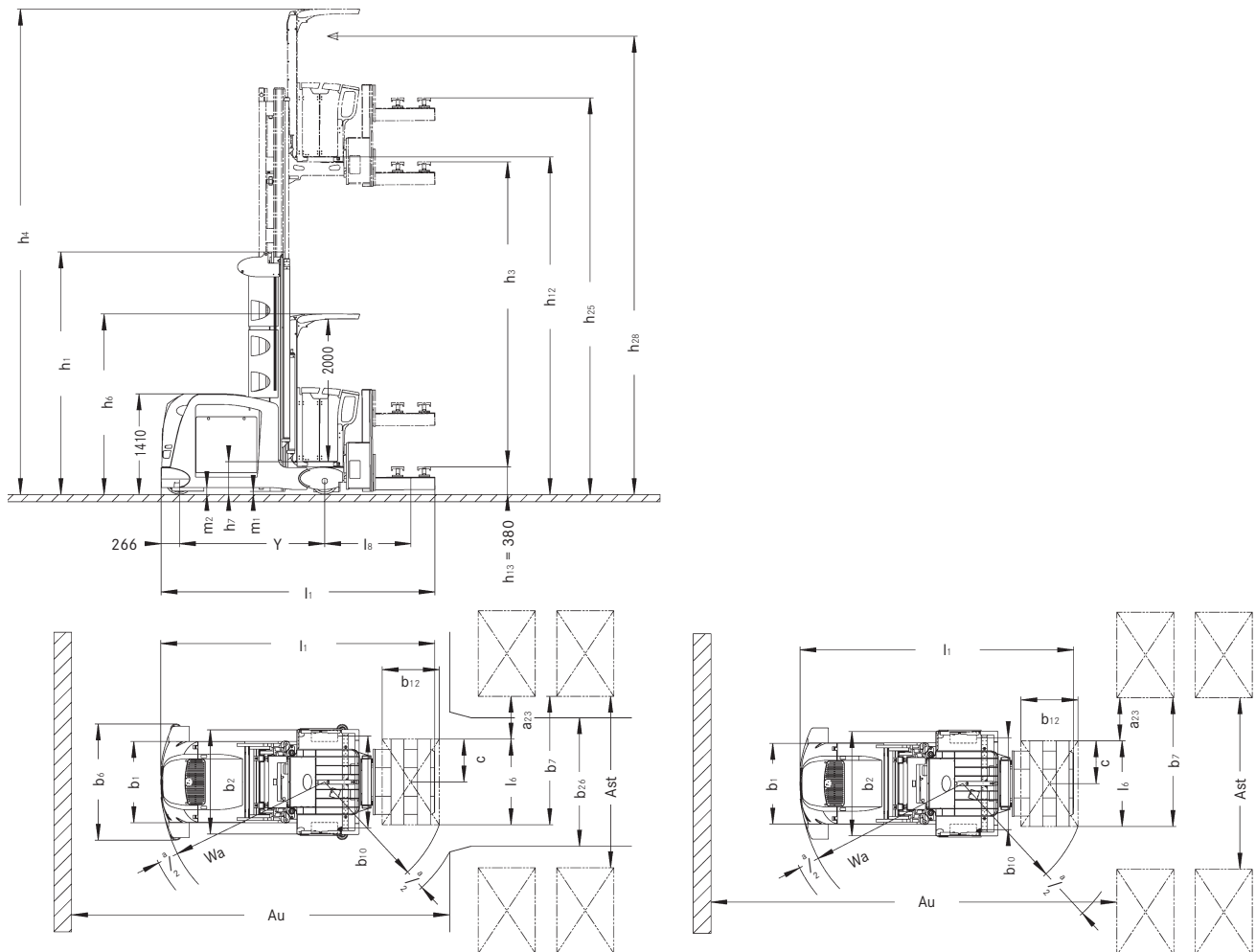

Standard Telescopic fork version.

- Narrow working aisles.
- Minimum space required for turning aisles.
- Capacity up to 1250 kg max.

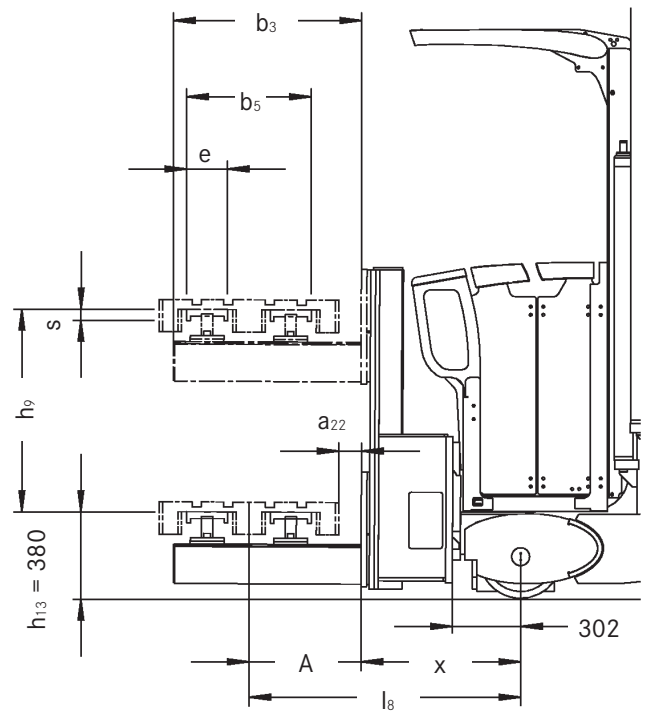

Standard Telescopic forks $h_{13} = 380$ mm									$a_{21} = 90$ mm	$a = 200$ mm	load
Model	$l_6 \times b_{12}$ pallet	A	a_{22}	x	l_8	h_9	b_3	b_7	Ast min.	Au min./soll	Q max.
MX-Q	1200 x 800	500	100	710	1210	variable*	1055	1290	1380	variable*	1250
	1200 x 1000	600	100	710	1310	variable*	1055	1290	1380	variable*	1000
	1200 x 1200	700	100	710	1410	variable*	1305	1290	1380	variable*	1000
	1240 x 835	500	82	710	1210	variable*	1055	1330	1420	variable*	1250
	1300 x 1300	700	50	710	1410	variable*	1355	1390	1480	variable*	1000

* The figures are scaleable and conform to the customer's individual requirements.

Low telescopic fork version.

- The lowest racking support can be as low as 100 mm above the floor, giving optimal utilisation of space in the bottom area of the racking.
- Narrow working aisles.
- Minimum space required for turning aisles.
- Capacity up to 1250 kg max.

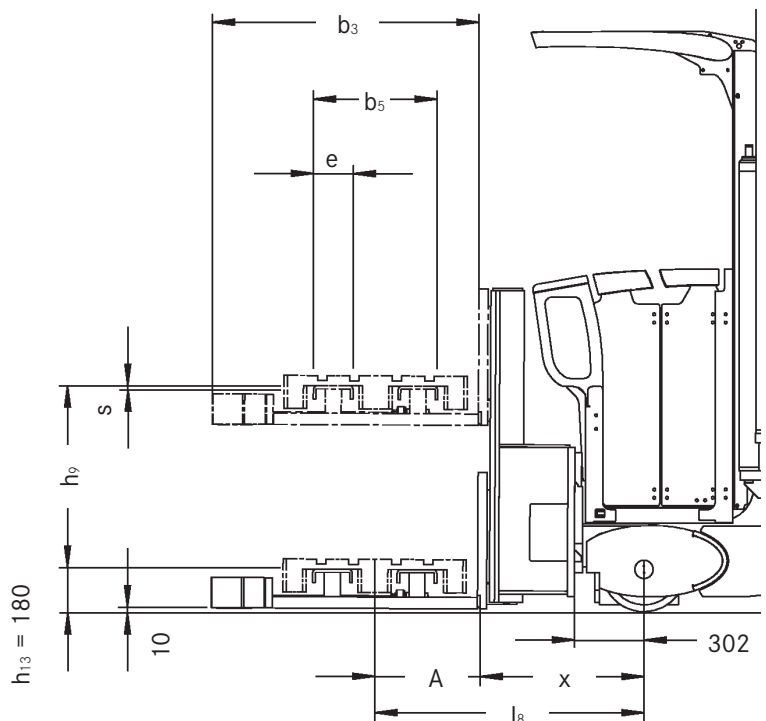

Low Telescopic forks $h_{13} = 180$ mm									$a_{21} = 90$ mm	$a = 200$ mm	load
Model	$l_6 \times b_{12}$ pallet	A	a_{22}	x	l_8	h_9	b_3	b_7	Ast min.	Au min./soll	Q max.
MX-Q	1200 x 800	450	50	725	1175	variable*	1165	1290	1380	variable*	1250
	1200 x 1000	550	50	725	1275	variable*	1365	1290	1380	variable*	1000
	1200 x 1200	650	50	725	1375	variable*	1565	1290	1380	variable*	800
	1240 x 835	450	30	725	1175	variable*	1165	1330	1420	variable*	1250
	1300 x 1300	700	50	725	1425	variable*	1665	1390	1480	variable*	800

* The figures are scaleable and conform to the customer's individual requirements.



Your contact

STILL GmbH
Berzeliusstraße 10
D-22113 Hamburg
Telephone: +49 (0)40/73 39-2000
Telefax: +49 (0)40/73 39-2001
info@still.de

For further information please visit:
www.still.de

STILL Materials Handling Ltd.
Aston Way, Leyland
Lancashire PR26 7UX
Telephone: +44 (0)1772 644300
Telefax: +44 (0)1772 644303
info@still.co.uk

For further information please visit:
www.still.co.uk