



## Your contact

STILL GmbH

Berzeliusstraße 10

D-22113 Hamburg

Telephone: +49 (0)40/73 39-2000

Telefax: +49 (0)40/73 39-2001

[info@still.de](mailto:info@still.de)

**For further information please visit:**

**[www.still.de/RX70](http://www.still.de/RX70)**



## RX 70 Technical data.

Diesel and LP gas forklift trucks

---

RX 70-22

---

RX 70-25

---

RX 70-30

---

RX 70-35

---

RX 70-30

Hybrid

---

RX 70-35

Hybrid

---



This specification sheet to VDI Guideline 2198 only gives the technical figures for the standard truck.  
Different tyres, other masts, additional equipment etc. could give different figures.

		STILL	STILL	STILL	STILL		
Characteristics	1.1	Manufacturer		RX 70-22	RX 70-22 TDI-PD	RX 70-22T	RX 70-25
	1.2	Manufacturer's model designation		Diesel	Diesel	LP gas	Diesel
	1.3	Truck type		Rider seated	Rider seated	Rider seated	Rider seated
	1.4	Operation					
	1.5	Capacity	Q t	2200	2200	2200	2500
	1.6	Load centre	c mm	500	500	500	500
	1.8	Load distance	x mm	430	430	430	430
	1.9	Wheel base	y mm	1700	1700	1700	1700
	Weights	2.1	Truck weight	kg	3630	3630	3630
2.2		Axle load, laden, front	kg	5049	5049	5049	5508
2.2.1		Axle load, laden, rear	kg	781	781	781	742
2.3		Axle load, unladen, front	kg	1646	1646	1646	1640
2.3.1		Axle load, unladen, rear	kg	1984	1984	1984	2110
Wheels   chassis	3.1	Tyres		SE	SE	SE	SE
	3.2	Tyre size, front		23 x 9-10	23 x 9-10	23 x 9-10	23 x 9-10
	3.3	Tyre size, rear		21 x 8-9	21 x 8-9	21 x 8-9	21 x 8-9
	3.5	Number of wheels front (x = driven)		2x	2x	2x	2x
	3.5.1	Number of wheels rear (x = driven)		2	2	2	2
	3.6	Track width, front	b <sub>10</sub> mm	984	984	984	984
	3.7	Track width, rear	b <sub>11</sub> mm	920	920	920	920
Basic dimensions	4.1	Tilt Mast/Fork carriage, forward	°	6	6	6	6
	4.1.1	Tilt Mast/Fork carriage, back	°	10	10	10	10
	4.2	Height, mast lowered	h <sub>1</sub> mm	2175	2175	2175	2175
	4.3	Free lift	h <sub>2</sub> mm	160	160	160	160
	4.4	Lift	h <sub>3</sub> mm	3020	3020	3020	3020
	4.5	Height, mast raised	h <sub>4</sub> mm	3650	3650	3650	3650
	4.7	Height over overhead guard (cab)	h <sub>6</sub> mm	2190	2190	2190	2190
	4.8	Seat/Platform height (SRP)	h <sub>7</sub> mm	1074	1074	1074	1074
	4.12	Coupling height	h <sub>10</sub> mm	425	425	425	425
	4.19	Overall length	l <sub>1</sub> mm	3570	3570	3570	3600
	4.20	Length including fork backs L <sub>2</sub>	l <sub>2</sub> mm	2570	2570	2570	2600
	4.21	Overall width	b <sub>1</sub> mm	1180	1180	1180	1180
	4.22	Fork thickness	s mm	40	40	40	40
	4.22.1	Fork width	e mm	100	100	100	100
	4.22.2	Fork length	l mm	1000	1000	1000	1000
	4.23	Fork carriage ISO 2328, Class/Form A, B		2/A	Kl. II, Form A	2/A	2/A
	4.24	Fork carriage width	b <sub>3</sub> mm	1040	1040	1040	1040
	4.31	Floor clearance under mast, laden	m <sub>1</sub> mm	125	125	125	125
4.32	Floor clearance, centre of wheel-base	m <sub>2</sub> mm	150	150	150	150	
4.33	Working aisle - 1000 x 1200 pallet crosswise	A <sub>st</sub> mm	3912	3912	3912	3942	
4.34	Working aisle - 800 x 1200 pallet lengthways	A <sub>st</sub> mm	4112	4112	4112	4142	
4.35	Turning radius	W <sub>2</sub> mm	2282	2282	2282	2312	
4.36	Smallest pivot point distance	b <sub>13</sub> mm	584	584	584	584	
Performance	5.1	Travel speed laden	km/h	21	21	21	21
	5.1.1	Travel speed unladen	km/h	21	21	21	21
	5.2	Hoist speed laden	m/s	0.51	0.58	0.53	0.51
	5.2.1	Hoist speed unladen	m/s	0.53	0.59	0.55	0.53
	5.3	Lowering speed laden	m/s	0.60	0.60	0.60	0.60
	5.3.1	Lowering speed unladen	m/s	0.53	0.53	0.53	0.53
	5.5	Drawbar pull laden	N	17500	17600	17500	17500
	5.5.1	Drawbar pull unladen	N	12140	12140	12040	12140
	5.7	Max. gradeability laden	%	29	28	29	29
	5.7.1	Max. gradeability unladen	%	26	26	26	26
	5.9	Acceleration time laden	s	5.2	4.7	5.2	5.2
5.9.1	Acceleration time unladen	s	4.6	4.3	4.6	4.6	
5.10	Service brake		electr./hydr.	electr./hydr.	electr./hydr.	electr./hydr.	
Engine	7.1	Engine manufacturer		VW	VW	VW	VW
	7.1.1	Type		BXT	CBHA	BEF	BXT
	7.2	Engine rating to ISO 1585	kW	30	44	36	30
	7.3	Rated speed	1/min	2600	2600	2600	2600
	7.4	No. of cylinders		4	4	4	4
	7.4.1	Swept volume	cm <sup>3</sup>	1900	2000	2000	1900
	7.5	Fuel consumption to VDI Cycle (60 runs/h)	Diesel LP gas l/h kg/h	2.4	2.6	2.5	2.5
Miscellaneous	8.1	Drive control		Stilltronic	Stilltronic	Stilltronic	Stilltronic
	8.2	Working pressure for attachments	bar	250	250	250	250
	8.3	Oil flow for attachments	l/min	-	-	-	-
	8.4	Sound level at driver's ear	dB(A)	77	77	77	77
	8.5	Towing coupler, Type/Model DIN		Pin	Pin	Pin	Pin

STILL	STILL	STILL	STILL	STILL	STILL
RX 70-25 TDI-PD	RX 70-25T	RX 70-30	RX 70-30T	RX 70-35	RX 70-35T
Diesel	LP gas	Diesel	LP gas	Diesel	LP gas
Rider seated	Rider seated	Rider seated	Rider seated	Rider seated	Rider seated
2500	2500	3000	3000	3500	3500
500	500	500	500	500	500
430	430	450	450	450	450
1700	1700	1700	1700	1700	1700
3750	3750	4200	4200	4530	4530
5508	5508	6326	6326	7065	7065
742	742	874	874	965	965
1640	1640	1650	1650	1610	1610
2110	2110	2550	2550	2920	2920
SE	SE	SE	SE	SE	SE
23 x 9-10	23 x 9-10	23 x 9-10	23 x 9-10	23 x 10-12	23 x 10-12
21 x 8-9	21 x 8-9	21 x 8-9	21 x 8-9	21 x 8-9	21 x 8-9
2x	2x	2x	2x	2x	2x
2	2	2	2	2	2
984	984	984	984	954	954
920	920	920	920	920	920
6	6	6	6	6	6
10	10	10	10	10	10
2175	2175	2175	2175	2175	2175
160	160	160	160	160	160
3020	3020	3020	3020	2820	2820
3650	3650	3800	3800	3700	3700
2190	2190	2190	2190	2195	2195
1074	1074	1074	1074	1074	1074
425	425	425	425	425	425
3600	3600	3705	3705	3770	3770
2600	2600	2705	2705	2770	2770
1180	1180	1180	1180	1194	1194
40	40	50	50	50	50
100	100	100	100	120	120
1000	1000	1000	1000	1000	1000
Kl. II, Form A	2/A	3/A	3/A	3/A	3/A
1040	1040	1100	1100	1100	1100
125	125	125	125	125	125
150	150	150	150	150	150
3942	3942	4037	4037	4127	4127
4142	4142	4237	4237	4327	4327
2312	2312	2387	2387	2477	2477
584	584	584	584	584	584
21	21	21	21	21	21
21	21	21	21	21	21
0.58	0.53	0.48	0.48	0.48	0.48
0.59	0.55	0.51	0.50	0.51	0.50
0.60	0.60	0.60	0.60	0.60	0.60
0.53	0.53	0.53	0.53	0.53	0.53
17600	17500	17600	17500	17400	17000
12140	12040	12080	12040	11840	11740
28	29	24	25	21	22
26	26	23	23	20	20
4.9	5.2	5.2	5.2	5.4	5.5
4.3	4.6	4.5	4.6	4.7	4.9
electr./hydr.	electr./hydr.	electr./hydr.	electr./hydr.	electr./hydr.	electr./hydr.
VW	VW	VW	VW	VW	VW
CBHA	BEF	CBHA	BEF	CBHA	BEF
44	36	44	38	44	38
2600	2600	2600	2600	2600	2600
4	4	4	4	4	4
2000	2000	2000	2000	2000	2000
2.7	2.6	2.8	2.9	3.0	3.1
Stilltronic	Stilltronic	Stilltronic	Stilltronic	Stilltronic	Stilltronic
250	250	250	250	250	250
-	-	-	-	-	-
77	77	77	77	77	77
Pin	Pin	Pin	Pin	Pin	Pin

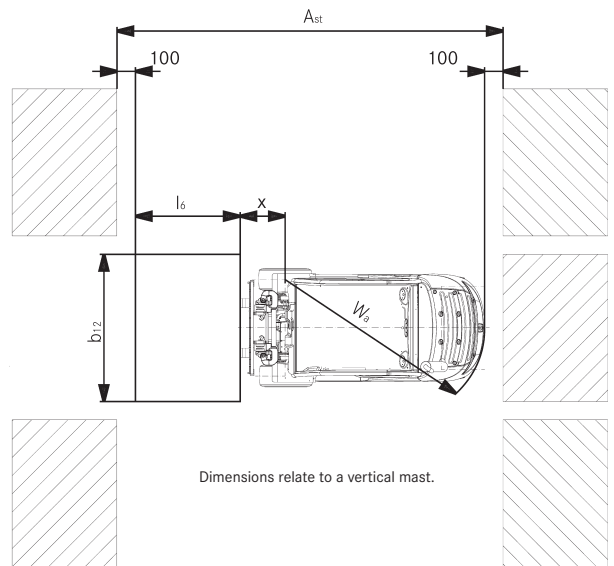
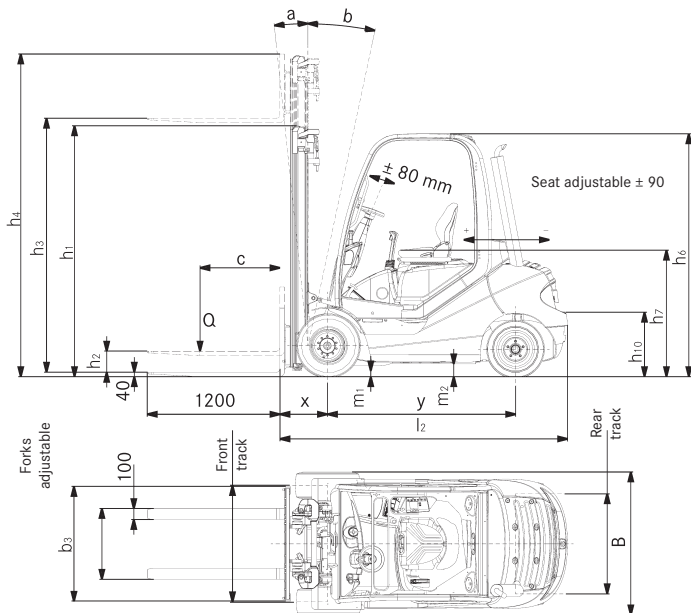

			Tele mast	HiLo mast	Triplex mast		
RX 70-22/25	Rated lift	$h_3$	mm	2320-5120	2500-4800	3580-5080	5230-7780
	Overall height	$h_1$	mm	1825-3225	1825-2975	1825-2325	2375-3225
	Free lift Form A	$h_2$	mm	160	1240-2390	1240-1740	1790-2640
	Free lift Form B	$h_2$	mm	160	1195-2345	1195-1695	1745-2595
	Greatest height Form A	$h_4$	mm	2950-5750	3090-5250	4185-5685	5835-8385
	Greatest height Form B	$h_4$	mm	2980-5780	3160-5280	4255-5755	5905-8455
	Forward tilt	a	°	6		6	
	Back tilt	b	°	10 (with front screen 8)		8	
	Load distance	x	mm	430		455	
	Tyres	v/h		23x9-10 // 21x8-9		23x9-10 // 21x8-9	
Greatest width (dual tyres)	B	mm	1180 (dual 1722)		1180 (dual 1722)	1280 (dual 1722)	
RX 70-22	Overall length	$L_2$	mm	2570		2595	
	Working aisle width	$A_{st}$	mm	(1000x1200)3912 // (1200x800)4112		(1000x1200)3937 // (1200x800)4137	
	Track	v/h	mm	984/920(dual=1220/920)		984//920(dual=1220/920)	1048//920(dual=1220/920)
RX 70-25	Overall length	$L_2$	mm	2600		2625	
	Working aisle width	$A_{st}$	mm	(1000x1200)3942 // (1200x800)4142		(1000x1200)3967 // (1200x800)4167	
	Track	v/h	mm	984/920(dual=1220/920)		984//920(dual=1220/920)	1048//920(dual=1220/920)

			Tele mast	HiLo mast	Triplex mast	
RX 70-30	Rated lift	$h_3$	mm	2320-5120	2390-4690	3430-7630
	Overall height	$h_1$	mm	1825-3225	1825-2975	1825-3225
	Free lift Form A	$h_2$	mm	160	1190-2340	1190-2590
	Free lift Form B	$h_2$	mm	160	1045-2195	1045-2445
	Greatest height Form A	$h_4$	mm	3100-5900	3080-5380	4110-8310
	Greatest height Form B	$h_4$	mm	3130-5930	3200-5500	4275-8475
	Forward tilt	a	°	6		6
	Back tilt	b	°	10 (with front screen 8)		8
	Load distance	x	mm	450		475
	Tyres	v/h		23x9-10 (23x10-12) // 21x8-9		23x10-12 // 21x8-9
Greatest width (dual tyres)	B	mm	1180 (1194) (dual 1722)		1280 (dual 1722)	
Overall length	$L_2$	mm	2705		2730	
Working aisle width	$A_{st}$	mm	(1000x1200)4037 // (1200x800)4237		(1000x1200)4062 // (1200x800)4262	
Track	v/h	mm	984(1048)/920 (dual=1220/920)		1048/920 (dual=1220/920)	

			Tele mast	HiLo mast	Triplex mast	
RX 70-35	Rated lift	$h_3$	mm	2120-4920	2190-4290	3130-7330
	Overall height	$h_1$	mm	1825-3225	1825-2875	1825-3225
	Free lift Form A	$h_2$	mm	160	1090-2140	1090-2590
	Free lift Form B	$h_2$	mm	160	1045-2095	1045-2445
	Greatest height Form A	$h_4$	mm	3000-5800	2955-5055	3810-8010
	Greatest height Form B	$h_4$	mm	3030-5830	3000-5100	3975-8175
	Forward tilt	a	°	6		6
	Back tilt	b	°	10 (with front screen 8)		8
	Load distance	x	mm	450		475
	Tyres	v/h		23x10-12 // 21x8-9		23x10-12 // 21x8-9
Greatest width (dual tyres)	B	mm	1194 (dual 1722)		1280 (dual 1722)	
Overall length	$L_2$	mm	2770		2795	
Working aisle width	$A_{st}$	mm	(1000x1200)4127 // (1200x800)4327		(1000x1200)4152 // (1200x800)4352	
Track	v/h	mm	1048/920 (dual=1220/920)		1048/920 (dual=1220/920)	

Basic Capacities RX 70-22 Tele/Full free lift HiLo mast

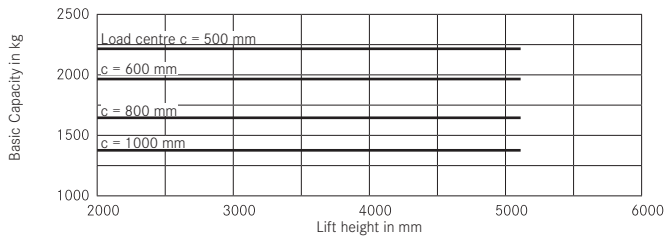

Basic Capacities RX 70-22 Triplex mast

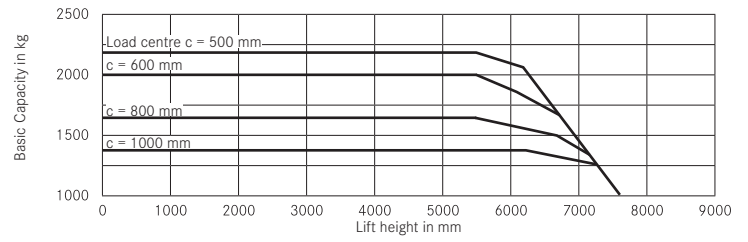

Basic Capacities RX 70-25 Tele/Full free lift HiLo mast

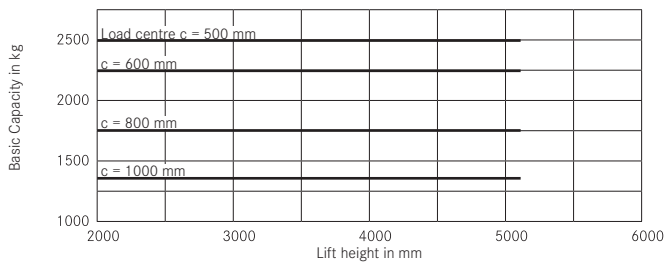

Basic Capacities RX 70-25 Triplex mast

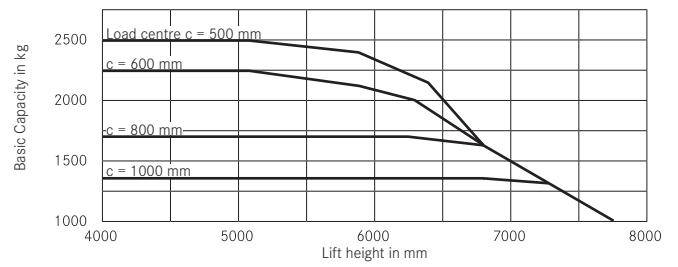

Basic Capacities RX 70-30 Tele/Full free lift HiLo mast

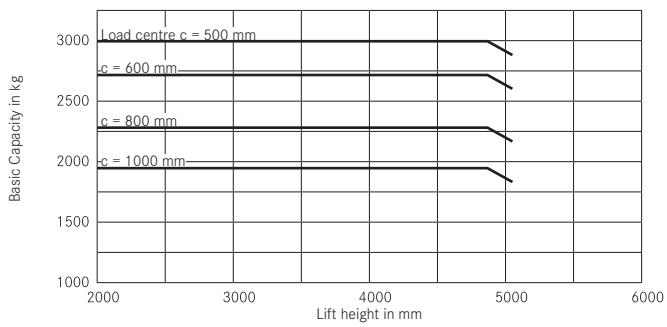

Basic Capacities RX 70-30 (7323 and 7327) Triplex mast

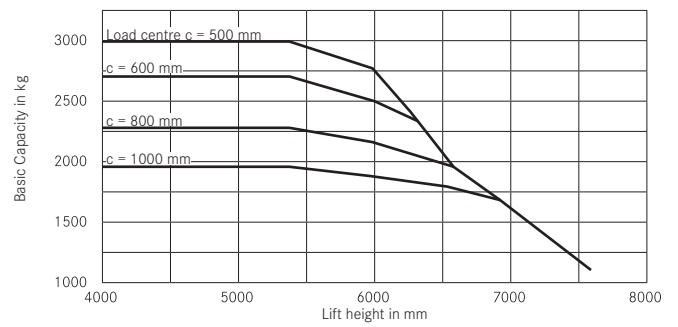

Basic Capacities RX 70-35 Tele/Full free lift HiLo mast

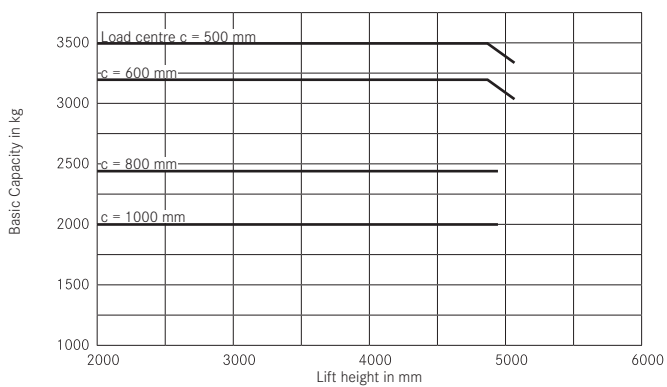

Basic Capacities RX 70-35 Triplex mast

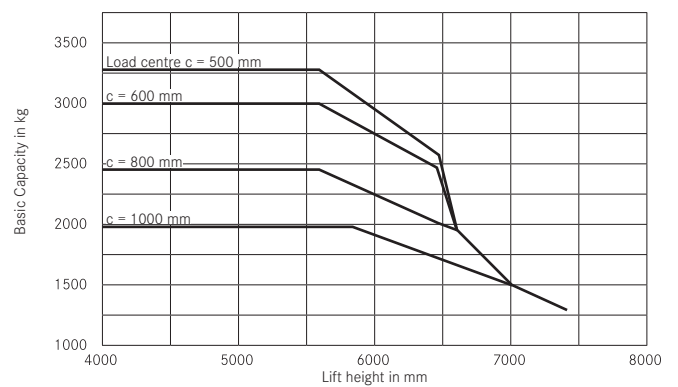

## Overall concept:

Engine powered four wheeled counterbalance forklift truck with front wheel drive.

The overall height of the truck supplied as standard is suitable for standard 8'6" containers.

## Drive.

- Engine-electric drive with hybrid technology.
- Modern diesel and gas engines with 3-phase generator.
- Gas truck with regulated 3-way Cat\*.
- Drive axle with enclosed 3-phase drive motor.
- Wear-free multi-disc brake running in oil bath.
- Hydraulic engine fan.

### Hybrid trucks\*

- Diesel-electric drive with recuperation of brake energy and storage of the energy in an electric energy storage system (Ultracaps)
- Use of the stored energy to accelerate the truck

## Ergonomics.

- Generously laid out driver's workplace.
- High driver comfort and operating convenience due to optimal arrangement of all controls.
- Excellent visibility to all sides.

## Safety.

- Low truck centre of gravity and an articulating steer axle for the best stability.
- High residual capacities even at high lifts.
- Excellent driving stability around bends - no electronic aids required.

## Environment.

- Very low fuel consumption in all types of work cycles
- Low emissions meeting directive 97/68/EG level 3a

### Hybrid trucks\*

- Eco-friendly and resource-saving hybrid drive
- Reduction of the conceptually low fuel consumption by another 20% per hour of operation
- Reduction of CO<sub>2</sub> emissions
- Reduction of noise emission by reducing the engine speed when lifting and driving

## Service.

- Long maintenance interval - 1000 operating hours.
- Quick fault identification in the event of damage due to computerised diagnostics.
- Optimal accessibility for maintenance.

\*Standard or optional equipment

## Technical features:

### Driver's workplace.

- Low, easy entry step.
- Long hand grip on overhead guard for different gripping heights.
- Large footwell with vibration inhibiting floor covering plus automotive arrangement of the pedals.
- Hydraulic servo steering with small steering wheel, ergonomic off-centre position, offset to the left.
- Narrow steering column without cumbersome display instruments.
- Central display of the drive direction plus change of drive direction in the field of view.
- Large display and operating unit to the right of the driver's workplace.

### Energy saving feature Blue-Q.

- Activation of the Blue-Q efficiency mode by pressing a button on the dashboard
- Energy saving by intelligent optimisation of the drive characteristics without impairing the work under progress
- Intelligent switch-off of electric equipment
- Possible energy saving depending on the application profile and truck equipment up to 10%

### Selectable drive parameters.

- Acceleration and braking of the truck can be carried out with just the drive pedal.
- Five drive stages adjustable by the driver.
- Individual setting of speed, acceleration and braking within each drive stage.
- Intelligent drive characteristics with engine speed reduction when the truck has finished accelerating.

### Electrical system.

- Designed in modern CAN bus technology.
- 12 Volt electrics.
- High-speed bus for drive unit regulation.
- Dedicated CAN bus for lighting and peripherals.
- Cable sets sheathed in corrugated tubing with water tight plug connectors.

### Mast and hydraulics.

- On demand delivery from hydraulic variable displacement pump for the working and steering hydraulics.
- Separation of hoist hydraulics and drive, so no inching required.
- Wide construction, open telescopic mast with and without full free lift and as a Triplex variant.
- Clear view fork carriage with open frame profile.

## **Additional equipment features (Optional):**

### **Truck equipment.**

- Superelastic or pneumatic tyres, single or dual versions.

### **Engine.**

- Gas truck with alternatives of gas bottle or tank.
- Regenerative soot particle filter in the counterweight or as a replaceable filter system.
- Wide core radiator and additional air filter for use in environments containing dust or fibres.

### **Cab equipment.**

- Modular construction cab with front, rear and roof screen.
- Rear mounted damped doors with large opening angles and windows sliding in opposite directions.
- Parallel screen wiper with large wiped area for front and rear screen, with screen washer as standard.
- Rear screen heater as standard.
- Unbreakable exterior and interior mirrors.
- Comfort seat variants with cloth cover, air sprung, seat heater, lumbar support, extended backrest.
- Radio/CD player housed in the interior lining of the overhead guard.

### **Controls.**

- Drive actuated by two pedal controls.
- Actuation of the hydraulic functions by Joystick or Fingertip control.

## **Electrical equipment and drive control.**

- Tempomat.
- Automotive style lighting also approved for use on public highways.
- Working spotlights front and/or rear on the overhead guard.
- Components of the Materialflow Management System (MMS).
- FleetManager - Driver identification and control, analysis of truck operating data and accident recorder.
- Camera systems for mast and reversing.

## **Mast and hydraulics.**

- Auxiliary hydraulics for actuating functions on attachments.
- Various fork carriage widths and fork lengths.
- Attachments to suit each load.
- Hydraulic accumulator to damp shocks in the hydraulic system.