



Your contact

STILL GmbH

Berzeliusstraße 10

D-22113 Hamburg

Telephone: +49 (0)40/73 39-2000

Telefax: +49 (0)40/73 39-2001

info@still.de

For further information please visit:

www.still.de

STILL Materials Handling Ltd.

Aston Way, Leyland

Lancashire PR26 7UX

Telephone: +44 (0)1772 644300

Telefax: +44 (0)1772 644303

info@still.co.uk

For further information please visit:

www.still.co.uk



FV-X 12 (12 l)

FV-X 16 (16 l)

FV-X Technical Data.

Rider-seated high lift pallet truck.



In accordance with VDI guidelines 2198, this specification applies to the standard model only. Alternative tyres, mast types, ancillary equipment, etc. could result in different values.

Characteristics	1.1	Manufacturer		STILL	STILL	STILL	STILL		
	1.2	Manufacturer's model designation		FV-X 12	FV-X 12i	FV-X 16	FV-X 16i		
	1.3	Power supply (electric, diesel, petrol, gas, mains electric)		electric	electric	electric	electric		
	1.4	Control (hand, pedestrian, stand-on, rider-seated, order-picker)		Rider-seated	Rider-seated	Rider-seated	Rider-seated		
	1.5	Capacity/load	Q	kg	1200	1200	1600	1600	
	1.6	Load centre	c	mm	600	600	600	600	
	1.8	Load distance	x	mm	672 ²⁾	647 ^{2) 3)}	672 ²⁾	647 ^{2) 3)}	
	1.9	Wheelbase	y	mm	1475	1458 ³⁾	1475	1458 ³⁾	
	Weight	2.1	Weight (inc. battery)		kg	1260 ⁴⁾	1249 ⁴⁾	1260 ⁴⁾	1249 ⁴⁾
2.2		Axle loadings laden		kg	1317/1612 ⁴⁾	1270/1649 ^{3) 4)}	1336/1994 ⁴⁾	1280/2039 ^{3) 4)}	
2.3		Axle loadings unladen		kg	1262/468 ⁴⁾	1251/468 ⁴⁾	1262/468 ⁴⁾	1251/468 ⁴⁾	
Wheels Tyres	3.1	Tyres			polyurethane	polyurethane	polyurethane	polyurethane	
	3.2	Tyre size, drive end		mm	250x80/125x50	250x80/125x50	250x80/125x50	250x80/125x50	
	3.3	Tyre size, load end		mm	85x80	85x80	85x80	85x80	
	3.5	Wheels, number (x = drive wheel)			1x-2/4	1x-2/4	1x-2/4	1x-2/4	
	3.6	Track width, drive end	b ₁₀	mm	582	582	582	582	
	3.7	Track width, load end	b ₁₁	mm	380	380	380	380	
	Dimensions	4.2	Closed mast height		h ₁	mm	2220 ⁶⁾	2226 ⁶⁾	2220 ⁶⁾
4.3		Free lift		h ₂	mm	150 ⁶⁾	150 ⁶⁾	150 ⁶⁾	150 ⁶⁾
4.4		Lift height		h ₃	mm	3444 ⁶⁾	3444 ⁶⁾	3444 ⁶⁾	3444 ⁶⁾
4.5		Height, mast raised		h ₄	mm	3975 ^{4) 8)}	3981 ^{4) 8)}	3975 ^{4) 8)}	3981 ^{4) 8)}
4.6		Initialhub		h ₅	mm	-	80	-	80
4.7		Height over overhead guard.		h ₆	mm	2220 ⁶⁾	2226 ⁶⁾	2220 ⁶⁾	2226 ⁶⁾
4.9		Height of steering wheel		h ₁₄	mm	890	890	890	890
4.15		Height lowered		h ₁₃	mm	85	91	85	91
4.19		Overall length		l ₁	mm	2220 ⁵⁾	2225 ^{3) 5)}	2220 ⁵⁾	2225 ^{3) 5)}
4.20		Length to front face of forks		l ₂	mm	1070 ⁵⁾	1075 ^{3) 5)}	1070 ⁵⁾	1075 ^{3) 5)}
4.21		Overall width		b ₁	mm	886	886	886	886
4.22		Fork dimensions		s/e/l	mm	60/189/1150	60/189/1150	60/189/1150	60/189/1150
4.24		Fork carriage width		b ₃	mm	680	680	680	680
4.25		Overall fork width		b ₅	mm	564	564	564	564
Performance		5.1	Speed (laden/unladen)		km/h	8/10	8/10	7/10	7/10
	5.2	Lifting time (laden/unladen)		m/s	0.16/0.23	0.16/0.23	0.14/0.23	0.14/0.23	
	5.3	Lowering time (laden/unladen)		m/s	0.33/0.28	0.33/0.28	0.33/0.28	0.33/0.28	
	5.10	Brakes			electric	electric	electric	electric	
	Electric Motors	6.1	Drive motor, rating S2 = 60 min.		kW	3	3	3	3
		6.2	Hoist motor, rating at S3 = 15%		kW	3	3	3	3
		6.3	Battery to IEC 254-2; A, B, C, no			DIN A	DIN A	DIN A	DIN A
		6.4	Battery voltage, capacity K _s		V/Ah	24/440 (560-640)	24/440 (560-640)	24/440 (560-640)	24/440 (560-640)
		6.5	Battery weight +/- 5% (depending on manufacturer)		kg	372 (502)	372 (502)	372 (502)	372 (502)
	Other	8.1	Drive control			electronic	electronic	electronic	electronic
8.4		Noise peak at operator's ears		dB (A)	< 70	< 70	< 70	< 70	

²⁾ -10 mm with Triplex mast // ³⁾ with raised wheel arms // ⁴⁾ with Tele mast h₃ = 3.444 mm

⁵⁾ + 10 mm with Triplex mast // ⁶⁾ masts in accordance with table // ⁸⁾ + 554 mm with load backrest.

FV-X 12/FV-X 16											
Tele mast				HiLo mast				Triplex mast			
h ₁	h ₂	h ₃	h ₄	h ₁	h ₂	h ₃	h ₄	h ₁	h ₂	h ₃	h ₄
2220	150	3444	3975	2220	1689	3444	3975	2070	1539	4716	5247
2270	150	3544	4075	2270	1739	3544	4075	2220	1689	5166	5697
2370	150	3744	4275	2370	1839	3744	4275	2320	1789	5466	5997
2570	150	4144	4675	2570	2039	4144	4675				
2820	150	4644	5175	2820	2289	4644	5175				
FV-X 12i/FV-X 16i (with the initial lift)											
Tele mast				HiLo mast				Triplex mast			
h ₁	h ₂	h ₃	h ₄	h ₁	h ₂	h ₃	h ₄	h ₁	h ₂	h ₃	h ₄
2226	150	3444	3981	2226	1689	3444	3981	2076	1539	4716	5253
2276	150	3544	4081	2276	1739	3544	4081	2226	1689	5166	5703
2376	150	3744	4281	2376	1839	3744	4281	2326	1789	5466	6003
2576	150	4144	4681	2576	2039	4144	4681				
2826	150	4644	5181	2826	2289	4644	5181				

The STILL FV-X/FV-Xi.

This rider-seated high-lift pallet truck is designed for high goods turnaround in racking operations, loading and unloading lorries and also for the horizontal transport of goods up to 1600 kg. With an overall width of 880 mm and being a more compact design, the truck is ideal for use with normal commercial pallets in the loading and unloading of lorries. In addition to this, the FV-X/FV-Xi is extremely flexible in use, for order picking and as a working/lifting table.

Driver's compartment.

- Ergonomically laid out driver's area with individually adjustable luxury seat.
- A high level of driving comfort is achieved with the padded interior plus integral storage facilities for working papers and utensils.
- The non-slip footplate, damped by a gas spring, can be adjusted in height by 120 mm and can be smoothly adjusted to the individual driver's height simply by pushing a button.
- The controls fall easily to hand without changing grip and a clear layout avoids confusion. Drive direction and travel speed are controlled by a butterfly switch with integral buttons for hoist and lower functions.
- Footrests on the right of the footwell prevent fatigue during long horizontal transport runs.
- Standard display gives battery discharge, operating hours and fault code read-outs.

Chassis.

- Very good all round vision and a clear view onto the fork tips thanks to the new rounded chassis contours.
- Robust, torsionally rigid steel frame consists of drive section and load lifting section.
- A patented hinged section gives ideal access to the electrical components. Ease of servicing reduces maintenance costs.
- Good weight distribution and reduced point loading due to the 4-wheel principle - ideal for upper storey use.
- Patented friction aids on the fork tips allow non-slip pallet handling.
- Skids under the fork tips facilitate driving over thresholds and also entry into pallets from the side.
- Clear view mast in Tele and Triplex versions.

Steering.

- Full electric steering for 180° lock-to-lock movement without kickback. Steering wheel diameter of only 120 mm and 4½ turns guarantees fast, effortless steering.
- The steer motor is protected against shocks from uneven floors by a safety coupling.
- Automatic reduction of speed when driving round corners, thereby ensuring a high level of safety.

Drive.

- A robust 3.0 kW shunt wound drive motor provides quick acceleration and powerful ramp travel. Efficient energy utilisation due to the spur and bevel gear transmission.

Hydraulics.

- The hydraulic unit consists of a powerful, high efficiency 3.0 kW pump motor actuated via push buttons in the operating panel.
- Particularly sensitive control is achieved with the proportional valve technology fitted as standard for the main hoist.
- Automatic shut-off of the initial lift is achieved by an overload protection for the hydraulic pump - saving energy and reducing noise.

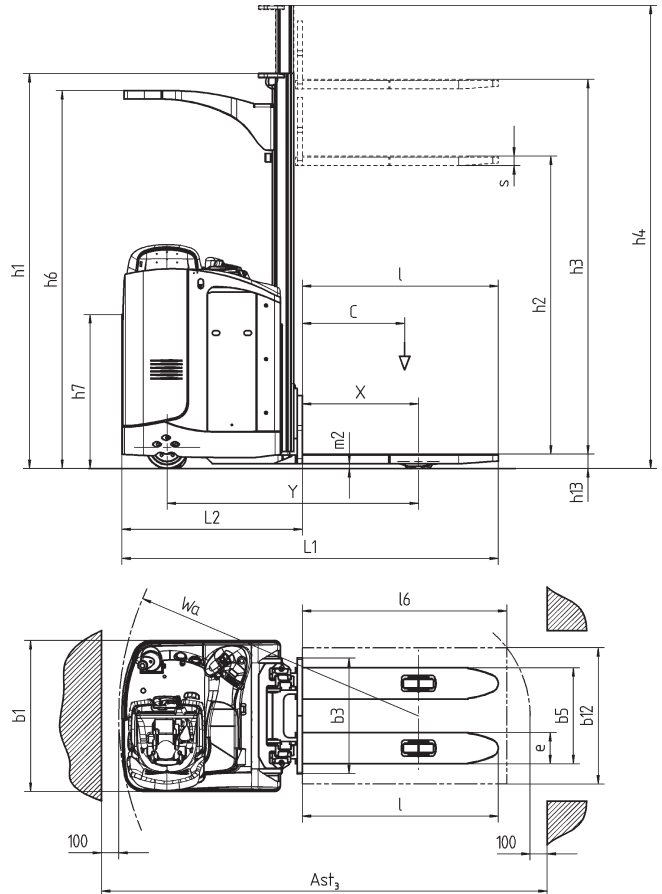

Brakes.

- Two independent braking systems are fitted.
- Generator braking activated by releasing the butterfly switch or changing drive direction guarantees soft braking and protects the brake linings. During braking the drive unit acts as a generator and puts the recovered energy back into the battery.
- An electromagnetic brake acts as a parking brake and emergency brake.
- Automatic brake monitoring is achieved by means of a load sensor, which regulates the braking current to suit the load.

Battery.

- For multi-shift use the battery is changed using the patented battery free lift and a roller track at the side.
- Double security thanks to two way interlock system.

Auxiliary equipment.

- Wheel position indicator.
- Reverse steering.
- FleetManager light.
- Provision for data terminal.
- Writing surface with document clip.
- Cold store version.
- Digisound (acoustic signal).
- PIN code access authority.